



HEAD RUSH TECHNOLOGIES WHITE PAPER

EMERGENCY ARREST DEVICE

JANUARY 2017

TABLE OF CONTENTS

WHAT IS AN EMERGENCY ARREST DEVICE?	3
EADs According to ASTM	3
EADs According to ACCT	3
WHEN IS AN EMERGENCY ARREST DEVICE REQUIRED?	4
When is an EAD Required According to ASTM	4
When is an EAD Required According to ACCT	4
When is an EAD Required According to HRT	4
DOES MY ZIP LINE REQUIRE AN EMERGENCY ARREST DEVICE?	5
According to ASTM	5
According to ACCT	5
<i>Determining Maximum Arrival Speed</i>	5
<i>Necessary Tools</i>	5
<i>Steps to Measure Arrival Speed</i>	5
WHEN IS AN EMERGENCY ARREST DEVICE NOT REQUIRED?	6
According to ASTM	6
According to ACCT	7
EMERGENCY ARREST DEVICE EXAMPLES	7
Spring Pack	7
<i>Spring Pack Pros</i>	8
<i>Spring Pack Cons</i>	8
zipSTOP/zipSTOP IR	8
<i>Example 1</i>	8
<i>Example 2</i>	9
<i>zipSTOP/zipSTOP IR Pros</i>	9
<i>zipSTOP/zipSTOP IR Cons</i>	9
BRAKES THAT ARE NOT EMERGENCY ARREST DEVICES	9
A single zipSTOP or zipSTOP IR	10
Inadequate Spring Pack	10
Hand Braking	10
Prusik Knot	10
Tire	11
Padding at Termination	11
CONCLUSION	11

WHAT IS AN EMERGENCY ARREST DEVICE?

Standards from both the Association for Challenge Course Technology (ACCT) and the American Society for Testing and Materials (ASTM) apply to zip lines and the braking systems. An emergency arrest device (EAD) is just what it sounds like – an apparatus that stops a rider in order to prevent injury or death if the primary brake does not perform as designed.

The definitions of emergency arrest device varies between standards:

- Head Rush Technologies refers to emergency brakes and fail-safe braking systems as EADs.
- ACCT refers to EADs as an emergency brake.
- ASTM refers to brake systems as fail-safe and does not use the phrase EAD or emergency brake.

EADs According to ASTM

Within ASTM 2959, a direct definition of an emergency brake or EAD is not made. In fact, the phrase EAD or emergency brake is not used at all. Instead, ASTM 2959 states that all braking systems within a zip line must be fail-safe. In order for a brake system to be fail-safe it must be, “designed such that the normal and expected failure mode results in a safe condition”. Meaning, if there is a possible failure mode in the brake system, an addition must be made to the brake system that creates a safe condition for the participant.

- **ASTM Definition of Brake System:** *As it applies to aerial adventure courses, examples of braking systems include, but are not limited to: longitudinal friction brakes, disc or drum brakes, motor end brakes, either onboard or off-board of the patron-carrying vehicle or device. If the failure of the braking system results in an unsafe condition, then the braking system shall be fail-safe.*
- **ASTM Definition of Fail-Safe:** *Characteristic of an aerial adventure course, or component thereof, that is designed such that the normal and expected failure mode results in a safe condition.*

EADs According to ACCT

ACCT standards mandate that zip lines have both a primary braking system and an EAD to ensure riders are stopped safely, effectively, and reliably at the end of the line. The ANSI/ACCT 03-2016 standard states that an EAD is required as a backup for all zip lines in which a participant arrives at the landing area at speeds in excess of 6 mph (10 kph) and where a participant may experience unintended and/or harmful contact with terrain, objects, or people in the landing area. Such a device shall require no action by the participant to engage, shall prevent injury or death, and shall engage separate from the primary brake.

- **ACCT Definition of Emergency Brake:** *A brake located on a zip line that engages without any participant input upon failure of the primary brake in order to “prevent serious injury or death”.*
- **ACCT Clarification on Emergency Brake:** *On zip lines that require an emergency brake, the emergency brake function may be integrated into the primary brake system as long as it acts independently from the primary brake.*

WHEN IS AN EMERGENCY ARREST DEVICE REQUIRED?

When is an EAD Required According to ASTM

In order to understand the requirements of ASTM, we must first understand a failure analysis.

A failure analysis, according to ASTM 2291, is a documented assessment which, "identifies the most significant factors of a zip line that may affect patron safety and shall include mitigation for each factor." Simply put, a failure analysis is a required document that states all possible items that could go wrong within the zip line and what has been done to mitigate the consequences. There is no question that a zip line's brake system has the potential to affect patron safety. Therefore, a failure analysis of a brake system must be completed by the designer/engineer of the zip line in order to meet ASTM standards.

During the failure analysis of the brake system, the designer/engineer of the zip line will most likely find that a certain aspect of the brake system has a normal and expected failure mode. If the failure mode results in an unsafe condition for the patron (e.g. hitting the termination pole of the zip line), another aspect must be added to the brake system in order to mitigate the potential for patron injury and ensure a fail-safe brake system.

ASTM 1193 states a requirement for Performance and Operational Testing that must be completed by the designer/engineer:

- **ASTM 1193: Performance Testing** – *this should consist of a series of specified tests that can be used to determine that the newly erected ride or device conforms to the original design criteria.*
- **ASTM 1193: Operational Testing** – *the manufacturer of an aerial adventure course shall develop specific operational tests along with minimum intervals for these tests to be performed that will allow the owner/operator of the aerial adventure course to determine whether a given ride or device is operating within prescribed operational limits.*

In accordance with ASTM 1193 the designer/engineer of the zip line must outline and perform a test procedure of the brake system that is based off the failure analysis document to ensure the brake system meets the fail-safe requirement. If a designer/engineer states that the zip line will meet ASTM standards, implying that the brake system will be fail-safe, they must perform testing to prove the installation meets such requirements.

When is an EAD Required According to ACCT

According to ACCT H.1.3 Emergency Brake Requirements: an emergency brake shall be required if, upon failure of the primary brake, both of the following may occur:

- *The participant arrives at the zip line landing area at a speed in excess of 6 mph (10 kph)*
- *The participant experiences unintended and/or harmful contact with terrain, objects or people in the zip line landing area*

In short, ACCT requires that the braking system is designed/engineered by the zip line installer, and that it incorporates an EAD for all zip lines where arrival speeds could be greater than 6 mph and the possibility of harmful contact within the landing area exists.

When is an EAD Required According to HRT

Head Rush Technologies mandates that an EAD must be used on all zipSTOP or zipSTOP IR installations. Using a zipSTOP or zipSTOP IR is prohibited in any installation which does not have an EAD that meets ACCT and ASTM standards. Head Rush discourages guide activated EAD's and includes them in our interpretation of the ACCT standard that states that the EAD should require no action by the participant. This is due to the fact that guides are typically the first participant descending a zip line. Additionally, when a primary brake does not engage, it typically occurs very quickly, es-

pecially on high speed lines, and a guide will likely not have time to react. The requirement stems from the ASTM and ACCT standards as described in this white paper.

DOES MY ZIP LINE REQUIRE AN EMERGENCY ARREST DEVICE?

According to ASTM

In order to meet ASTM Standards, the engineer/designer that built the zip line must produce a failure analysis, performance testing and operational testing document as outlined by ASTM 2291 and 1193. The documents provided by the engineer/designer of the zip line must state and prove that the brake system is fail-safe. If the brake system is not proven to be fail-safe by the engineer/designer, then additions must be made by the engineer/designer to ensure a fail-safe brake system.

According to ACCT

To determine if an EAD is required on a zip line two things must be done:

1. Determine maximum arrival speed of a participant.
2. Determine if it's possible for a participant to experience unintended and/or harmful contact with the terrain, objects, or people in the zip line landing area.

Determining Maximum Arrival Speed

Determining maximum participant arrival speed on a zip line is imperative to determine if an EAD is required. If done incorrectly and an EAD is not installed, it could result in participant injury or death. Luckily, measuring maximum arrival speed is not difficult if the following is done.

It must be noted that environmental conditions such as temperature, wind, and precipitation can have an enormous effect on participant arrival speeds. For example, rider arrival speeds can vary by 30 mph (48 kph) due to changing wind patterns. Therefore it's imperative to measure arrival speeds when the weather creates the fastest riding conditions for each zip line. For example, if a zip line experiences changing wind patterns, measure the arrival speed when there is a tail wind.

A rider will travel the fastest in cold weather, on a wet line, with a tail wind. It is vital to perform arrival speed testing when the environmental conditions create fast riding conditions. Otherwise the data collected will not reflect the zip line's maximum arrival speed and may result in participant injury or death.

Necessary Tools

- Radar Gun or other speed measuring device: Some options for radar guns are, Bushnell Velocity Speed Gun or an All Purpose Pocket Radar Gun. Other speed measuring devices are acceptable as long as the speed measured and recorded occurs immediately before braking is initiated.
- Weight bag(s) or sled capable of holding the minimum and maximum rider weight of the zip line.
- A rider trolley that is the same model as the trolley that will be used by the zip line participants.

Steps to Measure Arrival Speed

Important: Always perform unmanned testing to determine arrival speeds and to test any new or modified braking installations prior to sending individuals.

1. An operator at the terminal end of the zip line will take and record arrival speeds using the radar gun.

2. Attach the zip line's minimum participant weight to the rider trolley at the beginning of the zip line.
3. When the radar gun operator is ready, release the weight and rider trolley.
4. As soon as the rider trolley and weight are visible to the operator, they should point the radar gun at the rider trolley and begin measuring the speed.
 - a. If the Bushnell Velocity Speed Gun is used, it will begin to measure speeds when the rider trolley and weight are ~300 ft (91 meters) or closer from the operator.
5. Immediately before the rider trolley and weight engage the primary brake, the operator should evaluate and record the speed of the rider trolley.
 - a. **Please note:** The maximum speed shown by the radar gun is most likely not the arrival speed. It is likely that the zip line levels out near the terminal pole and riders speed decreases as they approach the primary brake. Be sure to record the speed immediately before the participant engages the primary brake. Always follow the manufacturer's directions of any speed measurement device. When using a radar gun, measurement should be taken in line with the direction of travel without moving the gun. Measurements taken from the side or at a high angle may be inaccurate.
6. Increase the test weight by 100 lbs (45 kg) and repeat Step 2-5, and increase the weight by 100 lbs (45 kg) after each test until the zip line's maximum participant weight is on the rider trolley.
 - a. It is likely that the fastest arrival speed will occur with the heaviest riders. However it is imperative to complete the full spectrum of weight ranges to ensure full understanding of rider arrival speeds.
 - b. Repeating descents will help ensure accurate information is collected, especially for the heaviest/fastest trials.
7. Once unmanned testing has been complete and all aspects of the zip line are working properly, repeat Steps 2-6 with participants of varying weights.
 - a. The first participant should weigh close to the zip line's minimum participant weight. The last should be close to the zip line's maximum participant weight.
8. Once all arrival speeds for the participant testing have been recorded, the highest of those values is the zip line's "maximum arrival speed".

Note for zip lines that utilize hand braking: According to ACCT Standards Appendix C: *The hand brake is often accompanied with the effect of deceleration by gravity, so the two methods together, along with a proper level of instruction, could suffice as the primary brake in the system.*

If the hand brake were to fail (e.g. braking glove falls off the participant) the primary brake would be compromised, resulting in the participant potentially arriving at the terminal platform at speeds greater than 6 mph (10 kph). Therefore, zip lines that utilize hand braking must perform the above unmanned testing without any hand braking to determine if an EAD is required.

WHEN IS AN EMERGENCY ARREST DEVICE NOT REQUIRED?

According to ASTM

It is up to the engineer/designer that built the zip line to determine whether an EAD is necessary to ensure the brake system is fail-safe. If the engineer/designer deter-

mines, through failure analysis, performance testing and operational testing that the brake system is fail-safe without an EAD, than it may not be required.

According to ACCT

According to ACCT, there are two situations where an EAD may not be required. The first is if gravity is the sole braking method. The second is if arrival speeds, without any form of braking (other than gravity), are less than 6 mph (10 kph).

ACCT has outlined that when gravity and only gravity is used to brake the zip line participant and there is no chance of harmful contact, an EAD is not necessary.

- *ACCT Appendix C states: "This [gravity] brake system is employed when at the end of the zip line traverse, the participant simply rolls back and forth in the belly of the zip line until coming to a stop. In this case, gravity is the only component of the primary brake, and if no possibility exists of striking anything during normal operations, the zip line will not require an emergency brake."*

ACCT also states that if the primary brake fails and arrival speeds are less than 6 mph (10 kph) that an EAD is not required. Head Rush would suggest considering conditions that exist, such as a tail wind, that could result in speeds greater than this, or if harmful contact with the terrain, objects or people is a possibility.

- *According to ACCT H.1.3 Emergency Brake Requirements: an emergency brake shall be required if, upon failure of the primary brake, both of the following may occur:*
 - *The participant arrives at the zip line landing area at a speed in excess of 6 mph (10 kph)*
 - *The participant experiences unintended and/or harmful contact with terrain, objects or people in the zip line landing area*

EMERGENCY ARREST DEVICE EXAMPLES

According to ACCT, an emergency brake is, "A brake located on a zip line that engages without any participant input upon failure of the primary brake in order to prevent serious injury or death."

Head Rush Technologies acknowledges that certain EADs provide better braking than others, however we do not endorse any particular type or brand of EAD. As long as an EAD meets ACCT and ASTM standards, provides a fail-safe braking system, is deemed adequate by a qualified professional, and provides smooth and controlled participant deceleration, it can be implemented. Below is a list of EAD examples that have been found to be viable, when designed, installed and tested by a reputable zip line designer/engineer.

Spring Pack

Spring packs have been found to be an effective EAD. A spring pack is made up of multiple springs which are approximately one foot in length connected by plastic spacer blocks. The number of springs necessary for each zip line EAD depends on rider arrival speed, weight range of riders, what type of primary brake is used as well as other variables. Only use spring packs designed specifically for zip line braking. Do NOT try to use other materials as springs for an EAD. Designers/installers should verify with zip line spring pack manufacturers to ensure the product is properly designed and installed to provide acceptable emergency braking in accordance with ACCT and ASTM.

When designed and installed properly, a spring pack can help to create a fail-safe braking system. It will consistently and effectively stop a participant in a safe condition.

Please be aware, that according to ASTM, a spring pack with too few springs does NOT create a fail-safe brake system. It is always better to overestimate the number



Spring Pack Brake



Figure 1: Spring Pack EAD

of springs in a spring pack EAD. If too few springs are used, the rider may bottom out the spring pack which may result in injury or death.

Spring Pack Pros

- Provides smooth and effective emergency braking when the correct number of springs are used
- Easy to install, inspect, and maintain
- Corrosion resistant due to the stainless steel springs and plastic spacer blocks
- Easy to add or subtract springs to ensure proper EAD function

Spring Pack Cons

- May require longer landing zone. The length of a spring pack, when used as an EAD, can be up to 75 feet (23 meters) or longer. The actual length of the spring pack must be determined by the spring pack manufacturer and the designer/engineer of the zip line.

zipSTOP/zipSTOP IR

A zipSTOP/zipSTOP IR may be used as an EAD. The Brake Trolley used with the EAD (zipSTOP/zipSTOP IR) must have adequate room to provide full braking for the participant should the primary brake malfunction.

Example 1

Below is an image of a zipSTOP IR mounted with a Pivot Mount used as the primary brake and a zipSTOP IR used as the EAD. To ensure the EAD zipSTOP IR is not engaged during standard use, the EAD Brake Trolley must be installed the maximum braking distance from the primary brake trolley. The maximum braking distance is defined as the longest distance the brake trolley needs to travel along the zip line to fully brake a participant during operation. The maximum braking distance will most likely occur with a heavy rider, on a cold day, in a tail wind. Maximum braking distance must be tested and verified prior to zipSTOP IR EAD installation. The distance between the EAD Brake Trolley and the end of the zip line (zip line termination) must be the maximum braking distance + a buffer to ensure the participant will not engage the zip line termination point. The maximum braking distance + buffer is required to ensure that the EAD Brake Trolley has adequate space to travel along the zip line in case of emergency braking. Please note that the below image is only one of multiple ways to install a zipSTOP/zipSTOP IR as an EAD.

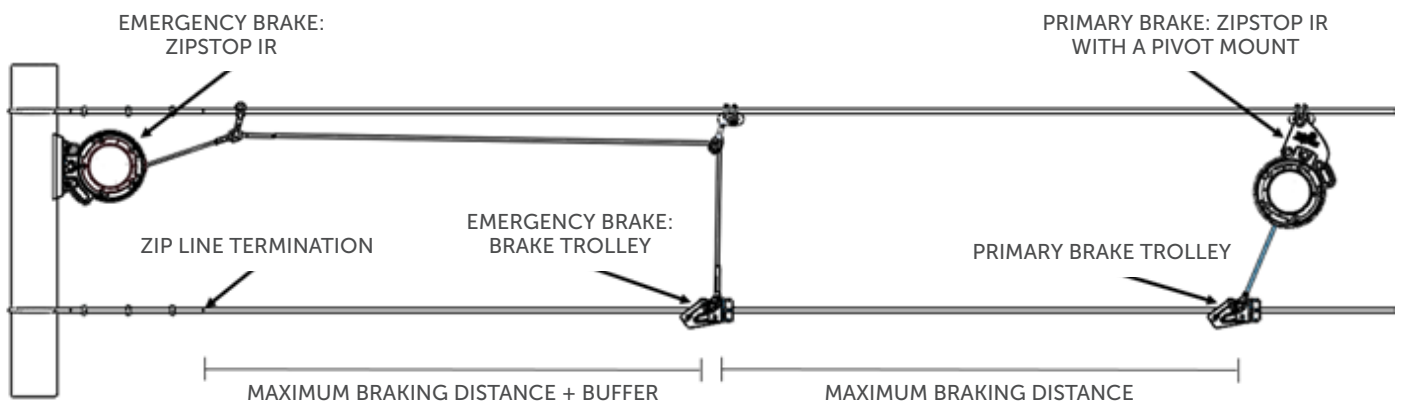

The ratio depicted above is for illustrative purposes only and should not be interpreted as how to properly install a zipSTOP or zipSTOP IR as a primary brake or EAD. All zipSTOP installations must be designed by a professional designer/installer in accordance with the zipSTOP manual, ACCT and ASTM.

Example 2

Below is an image of a standard zipSTOP in a 2:1 configuration used as the primary brake and a standard zipSTOP in a 2:1 configuration used as the EAD. The distance between the EAD Brake Trolley and the end of the zip line (zip line termination) must be the maximum braking distance + a buffer to ensure the participant will not engage the zip line termination point. The maximum braking distance + buffer is required to ensure that the EAD Brake Trolley has separate, adequate space to travel along the zip line in case of emergency braking. Please note that the below image is only one of multiple ways to install a zipSTOP/zipSTOP IR as an EAD.

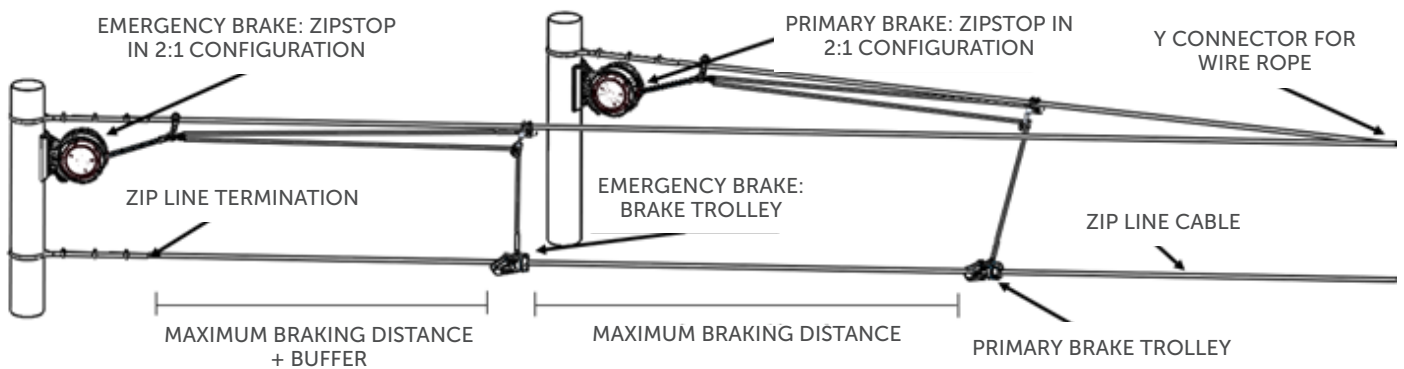

The ratio depicted above is for illustrative purposes only and should not be interpreted as how to properly install a zipSTOP or zipSTOP IR as a primary brake or EAD. All zipSTOP installations must be designed by a professional designer/installer in accordance with the zipSTOP manual, ACCT and ASTM.

zipSTOP/zipSTOP IR Pros

- Provides smooth and effective emergency braking that will not result in rider swing up or impact with the zip line
- Meets both ACCT and ASTM standards

zipSTOP/zipSTOP IR Cons

- May require large landing platform

BRAKES THAT ARE NOT EMERGENCY ARREST DEVICES

According to ACCT, an emergency brake is, "A brake located on a zip line that engages without any participant input upon failure of the primary brake in order to prevent serious injury or death." According to ASTM, a brake system must, "result in a safe condition". There are methods to stop participants upon nonperformance of the primary brake that engage without participant input, however they do NOT prevent injury or death and do NOT result in a safe condition. Below is a list of stopping methods that are NOT considered EADs and must NOT be used.

Please note these are only a few of the brakes that are NOT EADs. Any other brake method that creates abrupt braking that may result in participant injury should NOT be used as an EAD.

A single zipSTOP or zipSTOP IR

A zipSTOP or zipSTOP IR can be either a primary brake or an EAD, but a single zipSTOP CANNOT be both. According to the zipSTOP Manual:

- The zipSTOP is designed to be utilized as a Primary Brake or Emergency Arrest Device (EAD). When using the zipSTOP as a primary brake, the installer MUST utilize an independent EAD to protect against operator error and third party equipment failure. Design and installation of the zip line, including the complete braking system, is the responsibility of the installer or operator.

Inadequate Spring Pack

Spring packs have been found to be an effective EAD. However, a spring pack that is made up of too few springs does not meet ACCT or ASTM standards. For example, a spring pack that is not properly designed for the specific zip line may bottom out when engaged. The bottomed out spring pack may cause the rider to swing into the termination pole or other harmful object/terrain and result in serious injury or death.

It is the responsibility of the zip line designer/engineer to ensure that the spring pack EAD meets the requirements of the zip line spring pack manufacturer and is in accordance with ACCT and ASTM.

Hand Braking

According to ACCT Standards Appendix C: The hand brake is often accompanied with the effect of deceleration by gravity, so the two methods together, along with a proper level of instruction, could suffice as the primary brake in the system. Although hand braking can be considered part of a primary brake, it is NOT ever considered an EAD because it requires participant and/or operator input to engage. If a patron fails to hand brake, the resulting braking system will NOT result in a safe condition unless a proper EAD is implemented.

Prusik Knot

A prusik knot is NOT an EAD by ACCT or ASTM standards. A prusik knot, tied onto the zip line cable after the primary brake, is NOT an EAD because it may result in injury or death and does NOT result in a safe condition. When a participant engages a prusik knot, they may:

- Brake abruptly: which may result in the participant swinging into a harmful object or terrain. If a rider is traveling more than 6 mph (10 kph), it is possible that the swing up could result in injury or death.
- Not brake at all: which may result in the participant impacting the terminal structure.
- Brake in an unpredictable manner with varying results entirely dependent upon weather conditions, humidity, cable conditions, type-size-age of rope, etc.

Tire

A tire with a cable clamp holding the tire in place, mounted on the zip line cable, is NOT an EAD because it may result in injury or death and does NOT result in a safe condition. Therefore it does not comply with ACCT or ASTM standards. When a participant engages the tire, they will stop almost immediately, which may result in the participant swinging into a harmful object or terrain. If a rider is traveling more than 6

mph (10 kph), it is possible that the swing up could result in injury or death. A tire will degrade over time and when/if it degrades to the point of failure, a participant will break through the tire and hit the cable clamp directly.

Padding at Termination

According to ACCT Appendix C: It is generally understood that padding used as a protective element in the landing area does not constitute a brake component. A pad wrapped around the terminal pole of a zip line is NOT an EAD because impacting it may result in injury or death and it does NOT result in a safe condition. Therefore it does not comply with ACCT or ASTM standards.

CONCLUSION

Just as the primary brake is an essential component of an overall zip line installation, the EAD or emergency brake is just as critical to mitigate risk in an operation. ACCT defines an emergency brake as: A brake located on a zip line that engages without any participant input upon failure of the primary brake in order to prevent serious injury or death. There may be other emergency braking methods not outlined in this white paper, but all EADs must comply with ACCT and ASTM standards. The differences between correct and incorrect EADs, as documented above, can be the difference between life and death for a participant. It is imperative that zip line installers, designers and engineers include proper EADs in their installations. Properly designed and installed EADs greatly reduce the chance for participant injury or death which not only benefits the specific installation but the industry as a whole. Meeting or exceeding the requirements of industry standards will significantly reduce the risk involved in this exciting activity and build confidence in the industry.